

THIS INFORMATION IS CONFIDENTIAL AND IS DISCLOSED TO YOU ON CONDITION THAT NO FURTHER DISCLOSURE IS MADE BY YOU TO OTHER THAN TETULL PERSONNEL WITHOUT WRITTEN AUTHORIZATION FROM TETULL LTD.

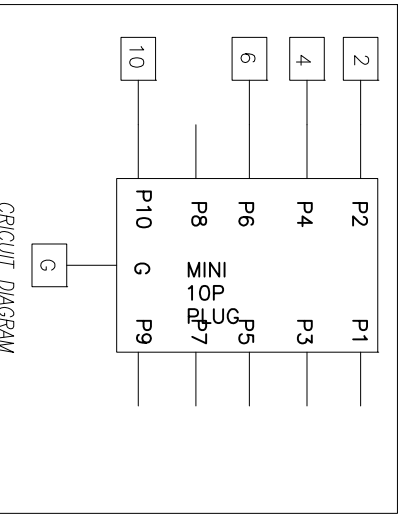
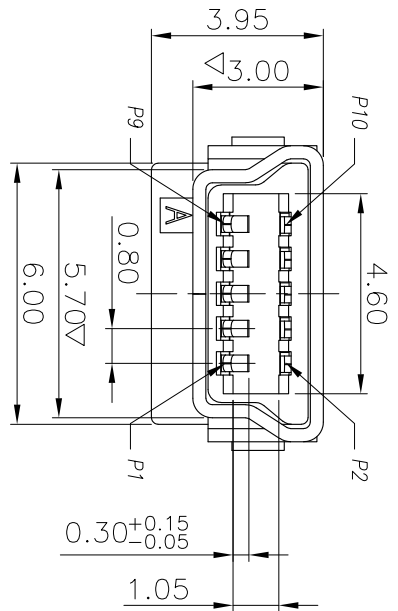
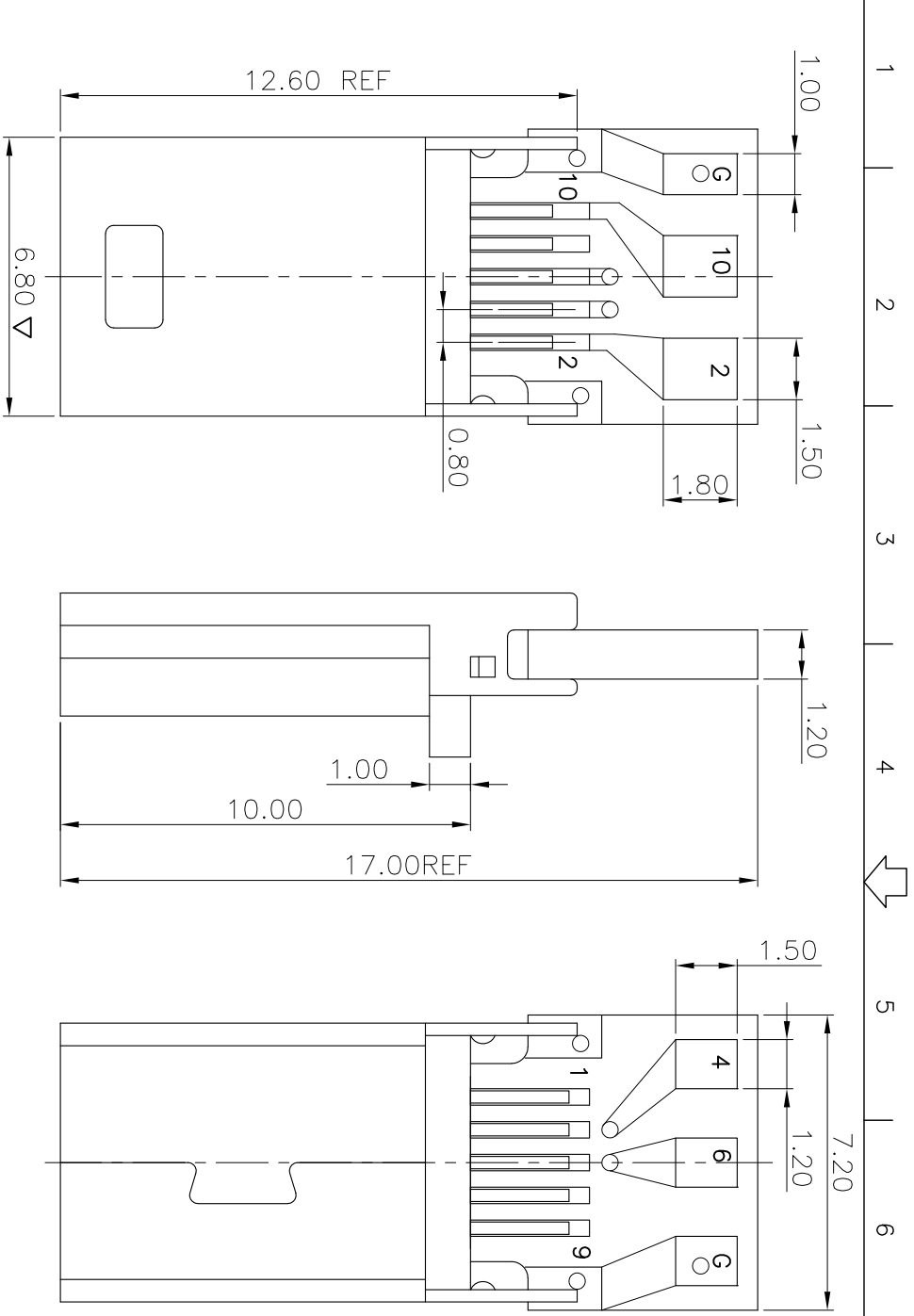

REV	ECN NO OR DESCRIPTION	REVISED	DATE
A	PRODUCT RELEASE	MKE	2020.01.11
B	BROKEN	BROKEN	2020.10.15

NOTE:

- ELECTRICAL CHARACTERISTICS
 - VOLTAGE RATING: 30V AC
 - CURRENT RATING: 2.0A
 - CONTACT RESISTANCE: 50 milliohms MAX.
 - INSULATION RESISTANCE: 100 Megohms MIN.
 - DIELECTRIC WITHSTANDING VOLTAGE: 500V AC FOR 1 MINUTE.
- MECHANICAL CHARACTERISTICS
 - MATING & UNMATING FORCE: 0.7kgf ~ 3.5kgf
 - DURABILITY: 10000 CYCLES
 - SALT SPRAY: 24H
 - OPERATING TEMPERATURE: -40°C ~ 85°C
 - ROHS 2002/95/EC COMPLIANT.
 - CRITICAL DIMENSIONS : ∇

NO	DESCRIPTION	QTY	MATERIAL	PLATING & COLOR
D	PCB	1	FR4-1	T-046
C	SHELL	1	SPCC 0.30t	NI
B	CONTACT	10	C5191 0.20t	Gold Flash On Contact Area Tin plated on Solder tail All over Nickel Plated.
A	HOUSING	1	LCP	BLACK

UNLESS OTHERWISE SPECIFIED TOLERANCES

DECIMALS: ANGLES:

X : ±0.5 X : ±2°
 X.X : ±0.3 X.X : ±1'
 X.XX : ±0.2

TITLE: MINI 10P 公头 绿 PCB 镀金 = 17.0 (5点2, 4, 6, 10, 0)

PART NO. 1031002GR076

DRAWN BROKEN 2020.10.15

CHKD

APVD

SCALE 1:1 UNIT: mm

CUSTOMER COPY SIZE: A4 SHEET: 10F1 REV: B